



# User Manual

Spend a little Live a lot

WITH

GUIDE



## TRAMPOLINE





# Contents

- Overview .....4**
- Scope of delivery/device parts.....6**
- General .....7**
  - Read and keep operating instructions .....7
  - Explanation of symbols .....7
- Safety .....8**
  - Intended use ..... 8
  - Safety instructions..... 8
- Notes about the location ..... 10**
- Unpacking ..... 10**
- Assembly ..... 10**
- Use.....11**
- Maintance and cleaning.....12**
- Technical data .....12**
- Disposal..... 13**
- Warranty card..... 15**
- Warranty conditions..... 16**



A

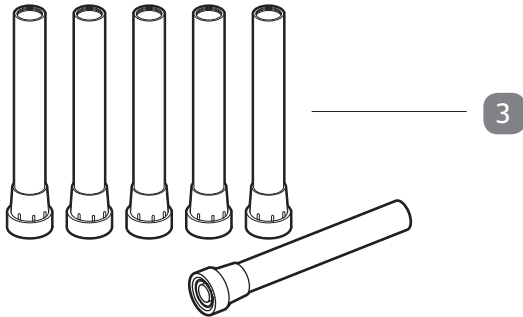
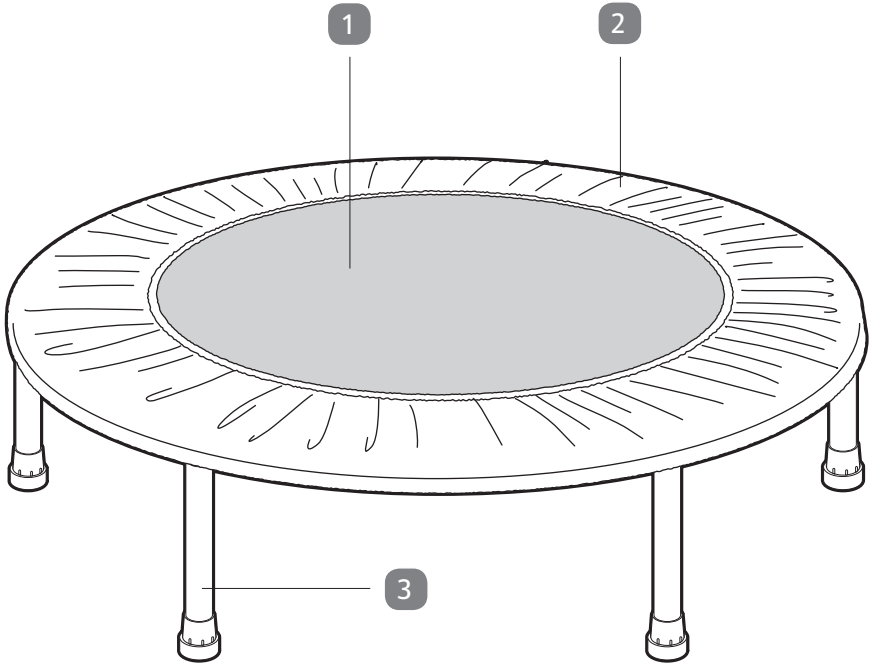

B

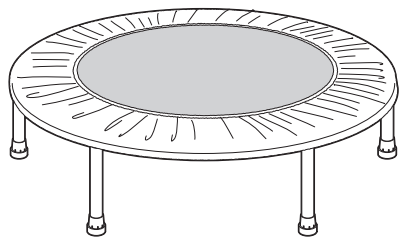
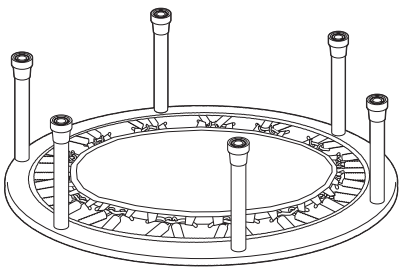
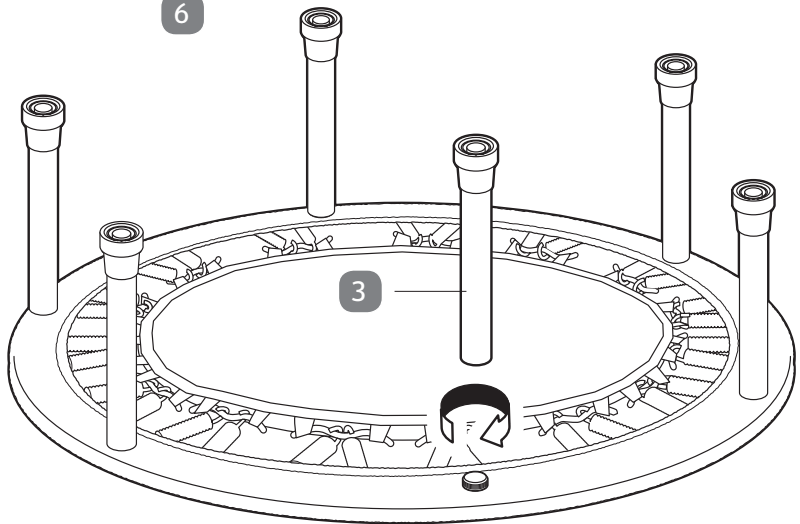
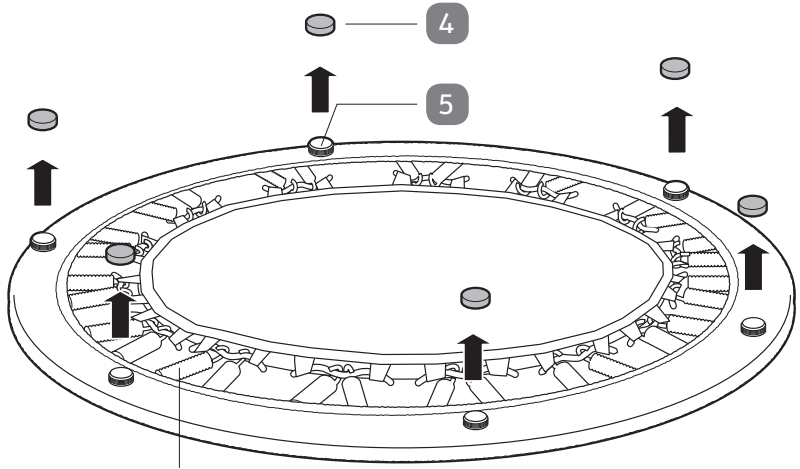

**GB**

**IRE**

## **Scope of delivery/device parts**

- 1 Jumping sheet
- 2 Protective cushion
- 3 Leg (6x)
- 4 Threaded protective caps (6x)
- 5 Threaded fittings (6x)
- 6 Coil springs (30x)

# General

## Read and keep operating instructions



These operating instructions belong to this remote-controlled car. They contain important information regarding initial use and handling.

Before using the trampoline, read through the operating instructions carefully, particularly the safety instructions. Failure to comply with these operating instructions can lead to serious injuries or damage to the trampoline.

The operating instructions are based on the valid standards and rules in the European Union. Please also note the country-specific directives and law abroad. Keep the operating instructions for further use. If you pass the trampoline on to third parties, please also ensure that you pass on these operating instructions.

## Explanation of symbols

The following symbols and signal words are used in these operating instructions, on the car or on the packaging.

 **WARNING!**

This signal symbol/word indicates a hazard with a medium degree of risk, which could lead to death or serious injury if it is not avoided.

**NOTE!**

This signal symbol/word warns of possible damage to property.



This symbol gives you useful information about assembly or operation.



This symbol indicates that the packaging should be recycled.

# Safety

## Intended use

This trampoline is exclusively suitable as an exercise apparatus and is only permitted for home use. It is unsuitable for any other use, e.g. as a child's toy or for therapeutic purposes.

It is not licensed for set-up or use in a commercial or professional studio area. Please note the information in these instructions. Improper use/excessive exercising can cause damage to health.

The trampoline is designed for a maximum load of 100 kg and may only be used by one person at a time.

## Safety instructions

### WARNING!

**Hazards for children and persons with impaired physical, sensory or mental capabilities (e.g. partially disabled, elderly persons with impairment to their physical and mental capabilities) or a lack of experience and knowledge (for example, older children).**

- This trampoline may be used by children from the age of 6 years under the supervision of an adult.
- Point out to children how important safety is when jumping on a trampoline. Explain the hazards to them, which can occur as a result of improper use.
- Do not let children play with the packaging film. They can become caught in it while playing and suffocate.

### WARNING!

### **Injury hazard!**

There is an injury hazard due to incorrect or careless use of the trampoline.

- If the trampoline is damaged, it must be repaired by the manufacturer or its customer service or a similarly qualified person, in order to avoid hazards for the user.



- Faulty or damaged parts must be replaced immediately. Exclusively use original spare parts for this.
- Do not make any structural modifications to the trampoline.
- The trampoline may only be used by one person at a time.
- Only jump in the middle of the trampoline and refrain from acrobatic jumps (e.g. somersaults), as this creates a significant risk of injury. Landing on the head or neck can result in paralysis or death!
- Never use the trampoline under the influence of alcohol, medications that impair awareness, drugs or if you are tired, exhausted, ill or lacking in concentration.
- Do not jump with a full stomach.
- Do not jump with strong or gusty wind.
- Never use the trampoline if parts are missing, damaged or not correctly fastened.
- Do not take any pointed or sharp objects onto the trampoline with you. Remove, e.g. jewellery, glasses, etc. and empty your trouser pockets, if necessary.
- Only use the trampoline if the jumping sheet is clean and dry. If it is raining, there is a higher risk of slipping.
- Be particularly careful when climbing onto and off of the trampoline. Never jump down off of the trampoline and never use the trampoline for jumping onto other objects. Also do not jump from other objects, e.g. a roof, onto the trampoline.
- Keep animals away from the trampoline.

### NOTE!

### Risk of damage!

Improper handling of the trampoline can result in damage.

- Always jump without shoes, i.e. only with socks or bare feet.
- Do not make any changes or modifications to the trampoline. Pay attention to the guarantee conditions.

## Notes about the location

- Adequate overhead clearance is essential. A minimum of 7,5 m from ground level is recommended.
- Provide clearance for wires, tree limbs, and other possible hazards. Lateral clearance is essential.
- Place the trampoline away from walls, structures, fences, and other play areas.
- Maintain a clear space on all sides of the trampoline.
- Use the trampoline in a well-lit area. Artificial illumination may be required for indoor or shady areas.
- Secure the trampoline against unauthorized and unsupervised use.
- Remove any obstructions from beneath the trampoline.
- The owner and supervisors of the trampoline are responsible to make all users aware of practices specified in the use instructions.

## Unpacking

1. Remove all of the parts from the packaging.
2. Check the trampoline and the accessories for possible transport damage.
3. Check whether all parts are complete (see **Fig. A**).

## Assembly

The trampoline is essentially delivered pre-assembled.



- Place the trampoline on a soft surface for assembly, e.g. on the packaging. This way, you will protect the protective cushion from possible damage.
- Keep the protective caps for later use, if possible.

1. Place the trampoline on the ground upside-down (see **Fig. B**).
2. Check whether all spring coils **6** are completely available on the underside and hooked in.
3. Remove the protective cap **4**.
4. Rotate the legs clockwise firmly into the threaded fittings **5**.
5. Carefully turn the trampoline over and place it on an appropriate, even surface (see “Information” section regarding set-up site).

The assembly is completed.



# Use

Detailed information regarding use of the trampoline can be found on the extra sheet enclosed.

Please note the following points before climbing onto the trampoline:

- Inspect the trampoline before each use. Inspect the trampoline before each use. Check whether the protective cushion and all springs are in place and correctly fastened.
- The jumping sheet must be clean, dry and undamaged.
- Children and beginners may need assistance when climbing on and off of the trampoline. They must also be supervised during use of the trampoline.
- Make sure the frame padding is correctly and securely positioned. Replace any worn, defective, or missing parts.
- Remove any items that may be lying on the trampoline. Items must never be on the trampoline.
- Stop bounce by flexing knees as feet come in contact with the trampoline bed. Learn this skill before attempting others.
- Learn fundamental bounces and body positions thoroughly before trying more advanced skills.
- A variety of trampoline activities can be carried out by performing the basic fundamentals in various series and combinations, performing one fundamental after another, with or without feet bounces between them.
- While keeping the head erect, focus eyes on the trampoline toward the perimeter. This will help control bounce.

# Maintenance and cleaning

## Maintenance

Inspect the trampoline before each use and replace any worn, defective, or missing parts. The following conditions could represent potential hazards:

- Missing, improperly positioned, or insecurely attached frame padding.
- Punctures, frays, tears, or holes worn in the bed or frame padding.
- Deterioration in the stitching or fabric of the bed or frame padding.
- Ruptured springs.
- A sagging bed.
- Sharp protrusions on the frame or suspension system.
- Broken or missing suspension elements or suspension elements disconnected to the bed edge.
- A bent or broken frame, or sharp protrusions on the frame.

## Cleaning

- Use a dry or damp cloth to clean the product. Do not use special cleaning agents to clean the trampoline.

## Store

- Store the product in a safe place where it cannot get damaged.
- Place the protective caps onto the threaded fittings if you are dismantling the trampoline for transport.

## Technical data

Model:	FLX-TR-01
Diameter:	env. 92 cm
Material:	Steel pipe, powder-coated
Load-bearing capacity:	env. 100 kg
Product code:	XXXXX

Because our products are constantly being further developed and improved, design modifications and technical changes are possible.

These operating instructions can also be downloaded as a PDF file from our website [www.flexxtrade.de](http://www.flexxtrade.de).

# Disposal

## Disposal of packaging



Dispose of the packaging such that it is correctly sorted. Submit cardboard and card to waste paper and foils to the recycling collection.

## Product disposal

Dispose of the car and remote control unit in compliance with the regulations that apply to your country.





# WARRANTY CARD

## TRAMPOLINE

Your details:

Name \_\_\_\_\_

Address \_\_\_\_\_

\_\_\_\_\_

\_\_\_\_\_



\_\_\_\_\_ E-mail \_\_\_\_\_

(for status reports for repair)

Date of purchase\* \_\_\_\_\_

\* We recommend you keep the receipt with this warranty card.

Location of purchase \_\_\_\_\_

Description of malfunction:

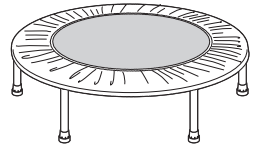

If after contacting the manufacturer you are requested to return the faulty product please return the completed warranty card together with it.

Flexxtrade Service Center  
Hotline: 00800 / 78747874

### AFTER SALES SUPPORT

**GB** 00800 / 78747874  
 **IRE**

**GB** flexxtrade-gb@teknihall.com  
 **IRE** flexxtrade-ie@teknihall.com

MODEL: FLX-TR-01

PRODUCT CODE: xxxxx

xx/xxxx

PO43000130



---

## Warranty conditions

Dear Customer,

The **ALDI warranty** offers you extensive benefits in addition to your statutory rights:

**Warranty period:** **3 years** from date of purchase.

**6 months** for wear parts and consumables under normal and proper conditions of use (e.g. rechargeable batteries).

**Costs:** Free repair/exchange.  
No transport costs.

<b>ADVICE:</b> Please contact our service hotline by phone, e-mail or fax before sending in the device. This allows us to provide support in the event of possible operator errors.
---

### **In order to make a claim under the warranty, please send us:**

- the faulty item together with the original purchase receipt and the completed warranty card.
- the faulty product with all components included in the packaging.

---

### **The warranty does not cover** damage caused by:

- **Accident** or **unanticipated events** (e.g. lightning, water, fire).
- **Improper use** or **transport**.
- **Disregard of the safety** and **maintenance instructions**.
- Other **improper treatment** or **modification**.

After the expiry of the warranty period, you still have the possibility to have your product repaired at your own expense. If the repair or the estimate of costs is not free of charge you will be informed accordingly in advance.

This warranty does not affect your statutory rights. The period of warranty can only be extended in accordance with a legal standard. In countries where a (compulsory) warranty and/or spare part storage and/or a system for compensation are/is required by law, the statutory minimum conditions apply. In the event that a product is received for repair, neither the service company nor the seller will assume any liability for data or settings possibly stored on the product by the customer.





Great care has gone into the manufacture of this product and it should therefore provide you with years of good service when used properly. In the event of product failure within its intended use over the course of the first 3 years after date of purchase, we will remedy the problem as quickly as possible once it has been brought to our attention. In the unlikely event of such an occurrence, or if you require any information about the product, please contact us via our helpline support services, details of which are to be found both in this manual and on the product itself.



**PRODUCED IN CHINA FOR:**

FLEXXTRADE GmbH & Co. KG  
Hofstr. 64  
40723 Hilden  
GERMANY

**AFTER SALES SUPPORT**

  00800 / 78747874   flexxtrade-gb@teknihall.com  
flexxtrade-ie@teknihall.com

MODEL: **FLX-TR-01**

PRODUCT CODE: **xxxx**

**xx/xxxx**

**3**  
YEARS  
WARRANTY