

Instruction Manual



VEHICLE SUPPORT STANDS, 2 PK





Contents

Overview	4
Use	5
Package contents/parts.....	6
General information.....	7
Reading and storing the user manual.....	7
Explanation of symbols	7
Safety	8
Proper use	8
Safety instructions	8
First use	12
Checking the jack stands and package contents	12
Jack stand assembly.....	12
Inserting the posts	12
Supporting a vehicle.....	14
Removing the jack stands.....	16
Maintenance, service and inspection	17
Cleaning and storage.....	18
Technical data	18
Disposal	19
Disposing of the packaging	19
Disposing of the jack.....	19
Warranty Details	
Repair and Refurbished Goods or Parts Notice	

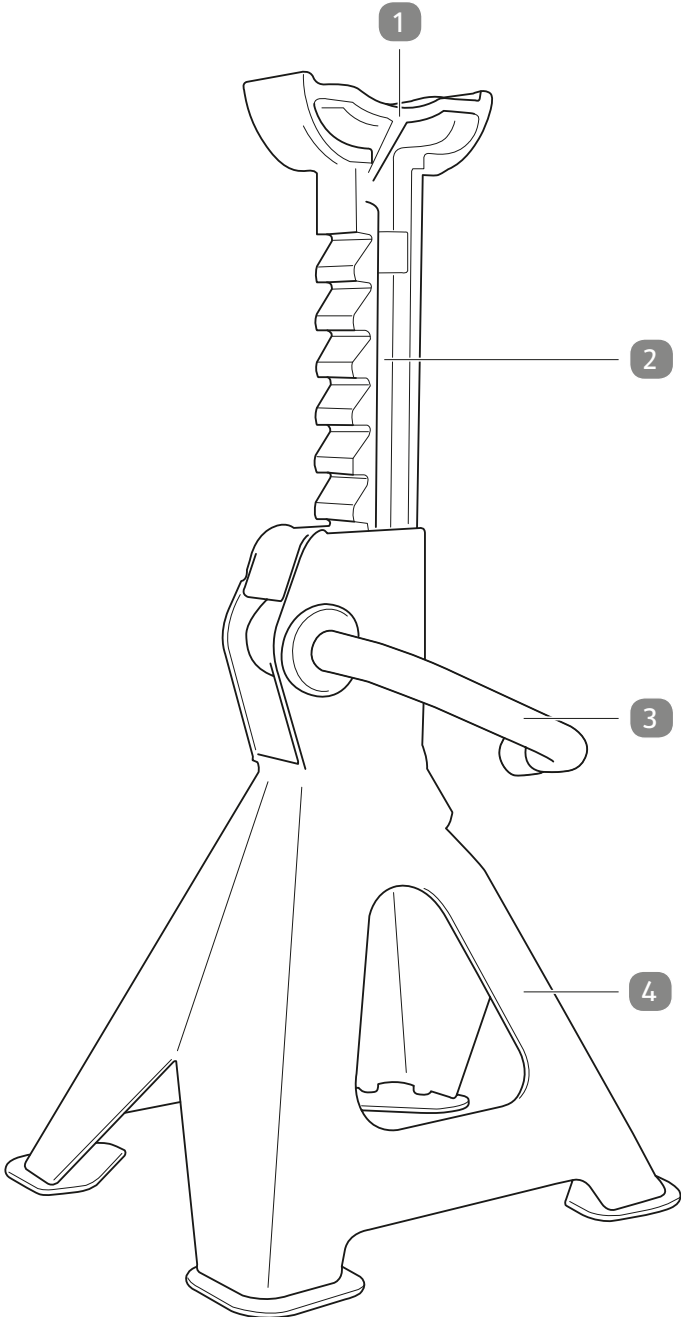

B

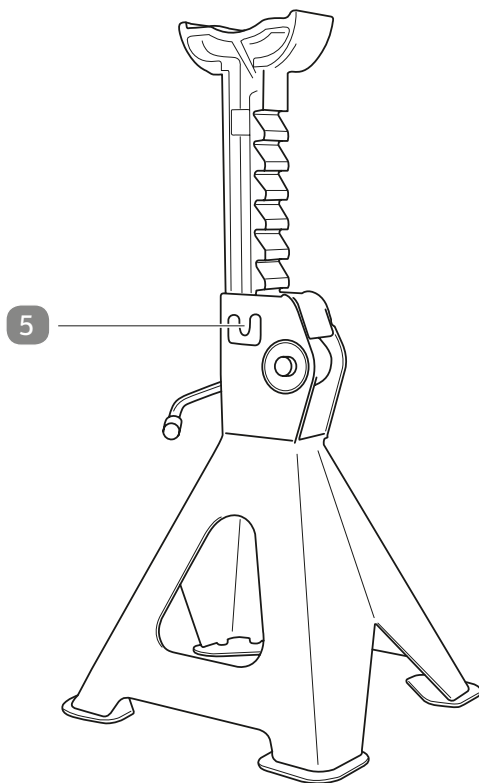

C

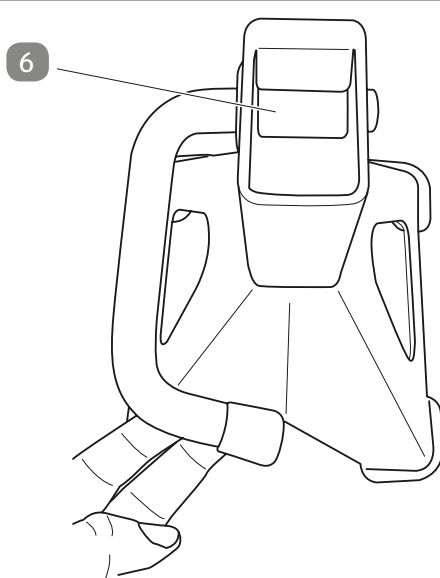

Package contents / parts

- 1 Head cap
- 2 Post
- 3 Handle
- 4 Base
- 5 Tab
- 6 Pawl

- User Manual / Warranty Card

General information

Reading and storing the user manual



This user manual accompanies these vehicle support stands, 2 pk (hereafter referred to as the support stands), and contains important information on setup and handling.

Before using the support stands read the user manual carefully. This particularly applies to the safety instructions. Failure to do so may result in personal injury or damage to the support stands.

Store the user manual for further use. Make sure to include this user manual when passing the support stands on to third parties.

Explanation of symbols

The following symbols and signal words are used in this user manual, on the support stands or on the packaging.



This signal symbol/word designates a hazard with a high degree of risk, which will result in death or severe injury if not avoided.



This signal symbol/word designates a hazard with moderate risk, which may result in death or severe injury if not avoided.



This signal symbol/word designates a hazard with low risk, which may result in minor or moderate injury if not avoided.



This signal symbol/word warns of possible damage to property.



This symbol provides you with useful additional information on handling and use.

SAFETY

Proper use

The vehicle support stands are exclusively designed for the shortterm support of vehicles not exceeding 2000 kg. They are only intended for private use and not suitable for commercial purposes.

Only use the support stands as described in this user manual. Any other use is considered improper and may result in damage to property or persons.

The manufacturer or vendor cannot be held liable for damages or injury incurred through improper or incorrect use.

Safety instructions



Risk of injury!

The operator of the support stands must have an understanding of the support stands and safe operating procedures before attempting to use them. Failure to do so may result in personal injury.

- Consult the vehicle’s user manual prior to lifting the vehicle.
- Always be sure to wear the appropriate personal protective equipment when using the support stands.
- Inspect the support stands for cracks or damage before each use. Do not use them if there are cracks, bends, damage, or deformation of any kind. Do not use the support stands if there are any loose parts or visible damage.
- Do not modify the support stands. Liability and warranty claims are waived in the event of repairs performed by the user, incorrect use or incorrect operation. If repairs are needed contact the manufacturer via the service address on the warranty card.

-
- Only parts that comply with the original support stands may be used for repairs. The support stands contain mechanical parts which are essential for providing protection against sources of danger.
 - Do not tamper with the support stands in any way and do not use any accessories.
 - Do not immerse the support stands in water or other liquids.
 - Keep the support stands away from open flames and hot surfaces.
 - Only use the support stands in dry weather or dry environments.
 - Do not use the support stands in damp indoor areas or in the rain.
 - Never store the support stands where they could fall and injure someone.
 - Do not exceed the rated capacity of the support stands.
 - Only use the support stands on hard, level surfaces.
 - Apply the parking break and chock the unlifted wheels before lifting a vehicle. (chocks not included)
 - Only set the vehicle on the support stands at the manufacturer recommended locations.
 - Always center the load on the head cap.
 - Only use a matching pair of support stands.
 - Only use the support stands to support one end of a vehicle. Do not use the stands to simultaneously support both ends of a vehicle.
 - Do not use the support stands for aircraft purposes.
 - Inspect the support stands before every use. Do not use them if parts are loose or damaged.
 - Only use the support stands in a clean and well-lit environment.
 - Keep children away from the support stands.



WARNING!

Danger for children and persons with impaired physical, sensory or mental capacities (e.g. partially

disabled persons, older persons with reduced physical and mental capacities) or lack of experience and knowledge (e.g. older children).

- The support stands may not be used by persons with impaired physical, sensory or mental capacities or those lacking experience and knowledge. Children may not use support stands. Cleaning and user maintenance must not be performed by children.
- Do not leave the support stands unattended while in use.
- Keep children away from the support stands.
- Do not let children play with the support stands.
- Keep persons with impaired sensory or mental capacities away from the support stands.
- Make sure that children do not play with any plastic wrapping. They may get caught in it when playing and suffocate.

**WARNING!****Risk of injury!**

Using the support stands in extreme or adverse conditions and environments may result in personal injury.

- Do not use the support stands in extreme or adverse weather conditions (e.g. extremely cold or hot climates, or in strong winds, or strong magnetic fields) as the support stands may not function properly and may cause injury.
- Do not use the support stands while on a ship. The vehicle will become unstable.

NOTICE**Risk of damage!**

Improper handling of the support stands may result in damage to the support stands.

- Always securely place the support stands (please refer to your vehicle's user manual for the correct position). The surface should be hard (e.g. concrete), stable, level and even and should be able to handle pressure of up to 2 tons.
- Do not put the support stands on a weak surface (e.g. grass). Weak surfaces may cause the vehicle to wobble and fall off the support stands resulting in damage and/or personal injury.
- Do not use the support stands if they are cracked, deformed or broken (see the chapter "Maintenance, service, and inspection"). Stop using them immediately and contact the manufacturer via the service address indicated on the warranty card.

First use

Checking the support stands and package contents

NOTICE

Risk of damage!

If you are not cautious when opening the packaging with a sharp knife or another pointed object, you may quickly damage the support stands.

- For this reason be very careful when opening it.
- 1. Check to make sure that all components and accessories have been received (see Fig. A).
- 2. Take the support stands out of the packaging and check whether they or any of the individual parts are damaged. If this is the case do not use the support stands. Contact the manufacturer via the service address indicated on the warranty card.

Jack stand assembly



WARNING!

Risk of injury!

Improper handling of the support stands can lead to smashing or pinching of fingers and hands.

- When lowering the posts, make sure your fingers and hands are not in between the head cap and base.

Inserting the posts

To assemble the support stands proceed as follows:

1. With the handle **3** of the base **4** on your left side, lift the handle up and lower the post **2** (ratchet side away from you), into the base.
Make sure the post is completely lowered.

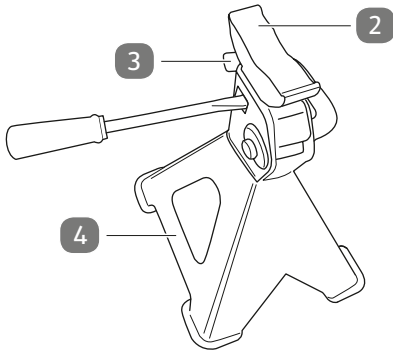

Figure 1

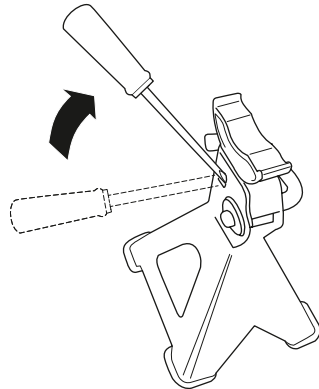

Figure 2

2. On the opposite side of the handle there is a tab **5** on the base. Using a large and sturdy flat-head screwdriver (not included), bend the tab in by placing the screwdriver under the tab and lifting up (see **Fig. 1** and **2**). Bend the tab in enough to keep the post from coming out of the base (see **Fig. 3** and **4**).
3. Repeat steps 1 and 2 for the other support stand.

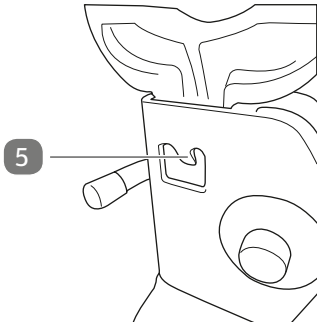

Figure 3

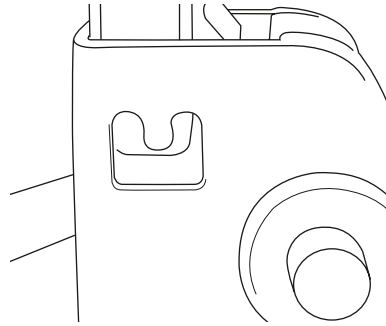

Figure 4

i Before using the support stands make sure the post cannot be pulled out of the base (see Fig. 4).

Supporting a vehicle



Risk of injury!

Using mismatched support stands may cause the vehicle to not be correctly supported and fall off the support stands, causing serious injury.

- Only use a matching pair of support stands to support a vehicle.
- Do not use the support stands as a permanent stand for a vehicle.
- Only use the support stands while making repairs to a vehicle, then immediately lower the vehicle to the ground.

i Capacity is defined as the evenly distributed weight per pair of support stands. Only apply the load vertically.

1. Make sure the vehicle does not exceed the capacity of the support stands.
2. Raise the handle **3** on each support stand to completely lower the post **2**.
3. Chock the wheels of the vehicle that will remain on the ground. (chocks not included)
4. Following the instructions in your floor jack manual, raise the vehicle to just above the minimum height of the support stands.
5. Slide the support stands to the proper position points referred to in the vehicle's user manual. Make sure the support stands are on the same point on each side of the vehicle.
6. Move the handle up and raise posts until they are just below the jack contact point on the vehicle.
7. Center the load on the head cap **1** of the post.
8. Release the handle so that a ratchet catches on the pawl **6**.
9. Gently lower the vehicle with the floor jack.
10. Repeat on the other side of the vehicle for the other support stand.
11. Ensure that the vehicle and support stands are stable and secure. There should be no rocking or other movement, no matter how slight. If in doubt, use the jack to lift the vehicle again, then reposition and resecure the vehicle on the support stands.

Removing the support stands



WARNING!

Risk of injury!

Improper use of the support stands may lead to damage and personal injury.

- Do not use the support stands as a permanent stand for a vehicle.
 - Only use the support stands while making repairs to a vehicle, then immediately lower the vehicle to the ground.
1. Raise the vehicle with a floor jack to take the load off of the support stands.
 2. Raise the handle **3** on each support stand to completely lower the Post **2**.
 3. Remove the support stands out from under the vehicle, being careful not to crawl underneath the vehicle.
 4. Use the floor jack to lower the vehicle to the ground.

Maintenance, service and inspection



CAUTION!

Risk of damage and injury!

A working area contaminated with oil can cause the support stands to slip and result in damage and/or personal injury.

- Thoroughly clean the area where the work will take place before using the support stands in this area.
- Always check the support stands before each use.
- Check for cracks, cracked welds, worn teeth on the post **2** and missing and/or loose and/or damaged parts. If the support stands appear to be damaged or deformed in any way, do not use them.
- If you believe that the support stands have been subjected to an abnormal load or shock the support stands must be inspected immediately by the manufacturer. Contact the manufacturer via the service address indicated on the warranty card.
- If the support stands have any problems, missing parts or are damaged, deformed or cracked, contact the manufacturer via the service address indicated on the warranty card.

CLEANING AND STORAGE

NOTICE

Risk due to improper operation!

An improper handling of the support stands may result in damage.

- Do not use any aggressive cleaners, brushes with metal or nylon bristles, or sharp or metallic cleaning utensils such as knives, hard scrapers and the like. They could damage the surfaces.
- Always store the support stands safely. Never store the support stands in such a way that they may fall.
- Clean the support stands with a damp cloth.
- Store the support stands in a secure place that is not accessible to children or animals.

Technical data

Model:	FLX-UB-01AUS
Minimum lift height:	280 mm
Maximum lift height:	435 mm
Number of locking positions:	10
Dimensions (area):	192 mm × 206 mm
Weight:	5.2 kg
Working load limit:	2000 kg

As our products undergo continual development and improvement, technical changes and changes to the product design are possible.

This user manual can be downloaded as a PDF file from our homepage **www.flexxtrade.de**

Disposal

Disposing of the packaging

- Sort the packaging before you dispose of it. Dispose of paperboard and cardboard with the recycled paper service and wrappings with the appropriate collection service.

Disposing of the support stands

- Should the support stands no longer be capable of being used at some point in time, dispose of them in accordance with the regulations in force in your city or state.



Vehicle support stands, 2 pk

Warranty Details

REGISTER YOUR PURCHASE AT www.aldi.com.au/en/about-aldi/product-registration/
TO KEEP UP-TO-DATE WITH IMPORTANT PRODUCT INFORMATION

The product is guaranteed to be free from defects in workmanship and parts for a period of 36 months from the date of purchase. Defects that occur within this warranty period, under normal use and care, will be repaired, replaced or refunded at our discretion. The benefits conferred by this warranty are in addition to all rights and remedies in respect of the product that the consumer has under the Competition and Consumer Act 2010 and similar state and territory laws.

Our goods come with guarantees that cannot be excluded under the Australian Consumer Law. You are entitled to a replacement or refund for a major failure and for compensation for any other reasonably foreseeable loss or damage. You are also entitled to have the goods repaired or replaced if the goods fail to be of acceptable quality and the failure does not amount to a major failure.

AFTER SALES SUPPORT

1800 269 981

Free of charge, mobile networks may vary

support@eurocentra.com.au





Vehicle support stands, 2 pk

Repair and Refurbished Goods or Parts Notice

REGISTER YOUR PURCHASE AT www.aldi.com.au/en/about-aldi/product-registration/
TO KEEP UP-TO-DATE WITH IMPORTANT PRODUCT INFORMATION

Unfortunately, from time to time, faulty products are manufactured which need to be returned to the Supplier for repair.

Please be aware that if your product is capable of retaining user-generated data (such as files stored on a computer hard drive, telephone numbers stored on a mobile telephone, songs stored on a portable media player, games saved on a games console or files stored on a USB memory stick) during the process of repair, some or all of your stored data may be lost.

We recommend you save this data elsewhere prior to sending the product for repair.

You should also be aware that rather than repairing goods, we may replace them with refurbished goods of the same type or use refurbished parts in the repair process.

Please be assured though, refurbished parts or replacements are only used where they meet ALDI's stringent quality specifications.

If at any time you feel your repair is being handled unsatisfactorily, you may escalate your complaint. Please telephone us on 1800 269 981 (Mon–Fri 8.30 am–6.00 pm AEST) or write to us at:

Euro Centra (Australia) Pty Ltd
c/o Install and Fix Solutions Pty
Unit 7, 210 Robinson Rd East, Geelong QLD 4034
AUSTRALIA
support@eurocentra.com.au

AFTER SALES SUPPORT

1800 269 981

Free of charge, mobile networks may vary

support@eurocentra.com.au



ALDI guarantees that our exclusive brand products are developed to our stringent quality specifications. If you are not entirely satisfied with this product, please return it to the nearest ALDI store within 60 days from the date of purchase, for a full refund or replacement, or take advantage of our after sales support by calling the supplier's Customer Service Hotline.



Made in China

Auto XS® is a registered trademark of ALDI Stores

DISTRIBUTED BY:

ALDI STORES

1 SARGENTS ROAD

MINCHINBURY NSW 2770

www.aldi.com.au

AFTER SALES SUPPORT

99257 



 **1800 269 981**



support@eurocentra.com.au

MODEL:

FLX-UB-01AUS

03 / 2020

3
YEARS
WARRANTY