



User Manual



AB WHEEL



Contents

Overview	3
Package contents/parts	3
Use	4
General information	5
Reading and storing the user manual	5
Explanation of symbols	5
Safety	6
Proper use	6
Safety instructions	7
First use	10
Checking AB Wheel and package contents.....	10
Assembly	10
Workout	11
Warm Up	11
Workout	11
Cool-down	11
Post-stretching.....	11
Exercises	12
Exercise 1	12
Exercise 2	12
Maintenance and care	13
Storage	13
Technical data	14
Disposal	14
Disposal of packaging.....	14
Disposing of AB Wheel.....	14

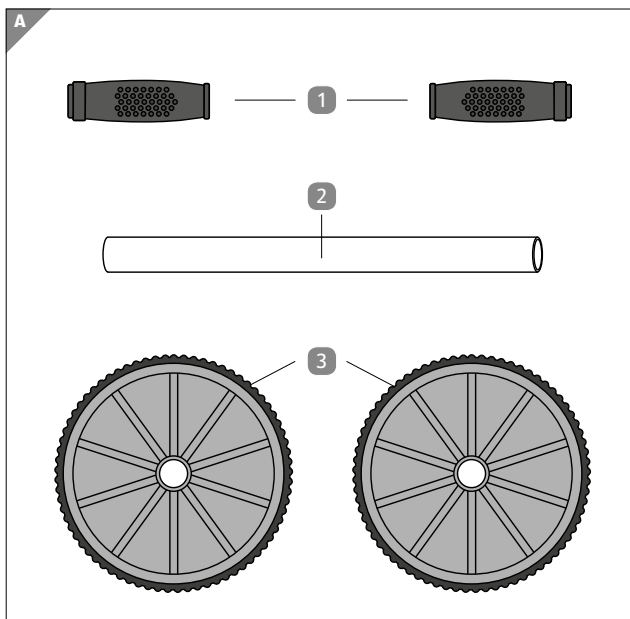

Package contents/parts

- 1 handles, 2×
- 2 metal axle, 1×
- 3 wheels, 2×

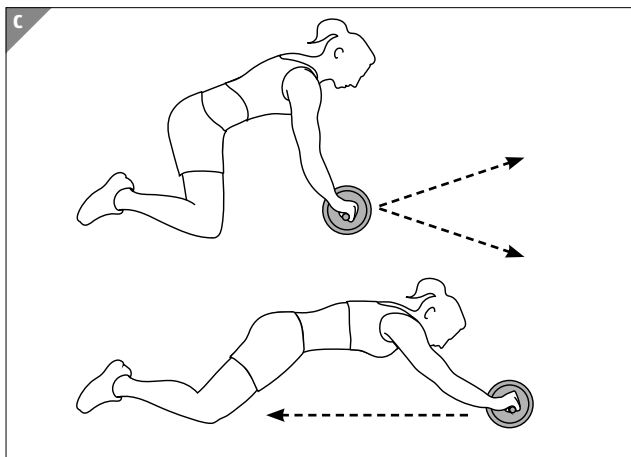
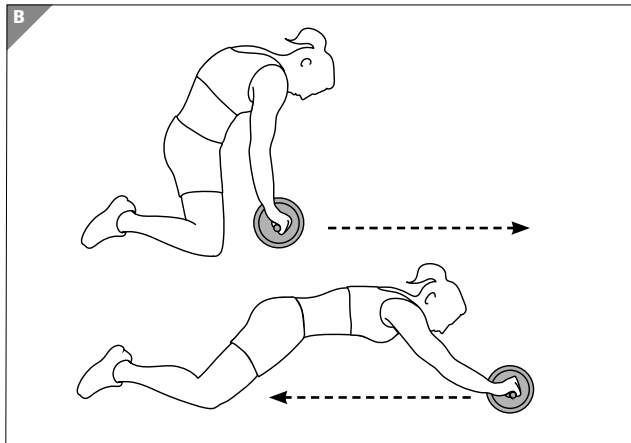

General information

Reading and storing the user manual



This user manual accompanies this AB Wheel, and contains important information on setup and handling. Before using the AB Wheel, read the user manual carefully. This particularly applies to the safety instructions. Failure to do so may result in personal injury or damage to the AB Wheel

Store the user manual for further use. Make sure to include this user manual when passing the AB Wheel on to third parties.

Explanation of symbols

The following symbols and signal words are used in this user manual, on the AB Wheel or on the packaging.



WARNING!

This signal symbol/word designates a hazard with a high degree of risk, which will result in death or severe injury if not avoided.



CAUTION!

This signal symbol/word designates a hazard with moderate risk, which may result in death or severe injury if not avoided.

NOTICE

This signal symbol/word warns of possible damage to property.

Safety

Proper use

The AB wheel is exclusively designed as training equipment. It is intended for private use only, not for commercial, medical or therapeutic applications

The AB wheel is not a toy.

Only use the AB Wheel as described in this instruction manual. Any other use is considered improper and can lead to material damage.

The manufacturer or retailer shall not accept any liability for damages caused by improper or incorrect use.

Safety instructions



WARNING!

Danger of suffocation!

If children play with the packaging film, they can get caught up in it, put it over their head or swallow it, and thus suffocate.

- Do not let children play with the packaging film. Children can get caught up in it and suffocate while playing.



WARNING!

Risk of injury!

Improper handling of the AB Wheel can lead to injuries.

- Be sure to consult your family doctor to determine or prevent any health risks before starting any exercise program. The advice of your physician will determine your pulse rate, blood pressure or cholesterol level.

- Observe your body signals. Improper or excessive training can endanger your health. If at any time during the training you experience pain, chest tightness, irregular heartbeat, extreme shortness of breath, dizziness or drowsiness, stop training immediately and consult your family doctor.
- Never exceed the user weight of 100 kg.
- Do not use the AB Wheel near stairs or landings.
- Keep children and animals away from the AB Wheel. It is intended for adults only.
- Use the AB Wheel on a firm, level and non-slip surface.
- Make sure that there is enough safety distance between you and furniture, walls, etc.
- Before each use, check the AB Wheel (e.g. for cracks). The safety of the AB Wheel can only be maintained if they are checked regularly.

**CAUTION!****Risk of injury!**

Improper handling of the AB Wheel can lead to injuries.

- Always wear suitable clothing during the training.
- Wear suitable shoes with non-slip soles.
- Keep a sufficient distance to other persons and/or objects during the use. Make sure that you do not injure yourself or others when using the product.
- The AB Wheel may not be used by more than one person at a time.
- The AB Wheel is not suitable for therapeutic use.

First use

Checking AB Wheel and package contents

NOTICE

Risk of damage!

If you open the packaging carelessly with a sharp knife or other sharp object, the AB Wheel can quickly be damaged.

- Be very careful when opening.
- 1. Remove the AB Wheel from the packaging.
- 2. Check whether the delivery is complete (see **Fig. A**).
- 3. Check whether the AB Wheel or the individual parts are damaged. If this is the case, do not use the AB Wheel.

Assembly

1. Slide one of the handles ① onto the metal axle ②.
2. Slide both wheels ③ onto the metal axle ②.
3. Slide the remaining handle ① onto the metal axle ②.
4. Push the handles ① together so that handles ① and wheels ③ are a tight fit.

To disassemble the AB Wheel, pull the handles ① first, then pull the wheels ③ off the metal axle ②.

Workout

Warm-up

Your workout should always start with a warm-up. The more strenuous the subsequent training session, the more important it is to warm up. Warming up prepares the body for the strain, stimulates the cardiovascular system and protects ligaments, tendons and joints from injuries. It also helps to reduce the risk of cramps and muscle injuries. You should loosen your joints a little before starting your workout.

Workout

After getting used to the exercises, try to be innovative and develop your own training method. Combine different exercises and listen to music to enjoy your workout even more.

Cool-down

Just as a warm-up should be performed before each training session, a cool-down should be performed after each session. A cool-down initiates the relaxation phase, reduces the body's operating temperature again, and depicts the change from stress to relaxation.

Post-stretching

As mentioned earlier, you can easily pre-stretch your muscles while warming up. After the training you should stretch your muscles. A post-stretching brings the muscle back to its original length and thus prevents muscle shortening. The more strenuous the training, the more important the post-stretching is. Post-stretching is particularly important for the main muscle groups used during training. The stretching should be felt, but it shouldn't be painful. The stretching time is about 20 seconds for each muscle.

Exercise

Do not roll too far forward the first time, as it may be difficult to roll yourself back. Experiment with different forward roll lengths to determine the distance that your abdominal muscles can support.

Always move slowly and keep your abdominal muscles tight at all times. Use your torso to push you forward and roll you back.

Inhale while rolling forward, exhale while rolling back.

Exercise 1

(see **Fig. B**)

Take a kneeling position. Hold the AB Wheel with both hands and place it on the floor in front of you, place your toes on the floor and straighten your arms. This is the starting position.

Roll the AB Wheel in a straight line forward only as far as the lower back can maintain its natural curvature.

After a pause at the stretched position, start pulling yourself back to the starting position using your abdominal muscles.

Perform the exercise 10 to 25 times in three set.

Variation: On the knees, the feet are raised and crossed behind the buttocks.

Exercise 2

(see **Fig. C**)

Start in a kneeling position. Hold the AB Wheel with both hands and place it on the floor in front of you, place your toes on the floor and straighten your arms. This is the starting position.

When rolling, move in a slight curve to the left. After a pause at the stretched position, start pulling yourself back to the starting position using your abdominal muscles.

Now, move on now while rolling in a slight curve to the right and go back.

Perform the exercise 10 to 25 times in three set.

Variation: On the knees, the feet are raised and crossed behind the buttocks.

Maintenance and care

NOTICE

Risk of damage!

Improper handling of the AB Wheel can lead to damages to the AB Wheel.

- Do not use aggressive cleaning agents, brushes with metal or nylon bristles or sharp objects to clean the AB Wheel as this can cause damage.
- Wipe the AB Wheel with a damp cloth.
- Allow to dry completely before storing away.

Storage

- Always store the AB Wheel in a dry place.

Technical data

Model:	FLX-ABW-02
Item Number:	812384
Weight:	455 g +/-5%
Handle width:	24.2 cm
Wheel diameter:	17.5 cm
Max. user weight:	100 kg

Disposal



Recycle

Disposal of packaging

Dispose of the packaging sorted by type. Dispose of cardboard and other related substances in the waste paper collection, and foils in the recyclable waste collection.

Disposing of AB Wheel

- Dispose of the AB Wheel in accordance with the laws and regulations applicable in your country.



If you are not entirely satisfied with this product please return it to the store where it was purchased and we will be pleased to replace or refund it. This does not affect your statutory rights.



PRODUCED IN CHINA FOR:

ALDI STORES LTD. PO BOX 26, ATHERSTONE
WARWICKSHIRE, CV9 2SH.

ALDI STORES (IRELAND) LTD.
PO BOX 726, NAAS, CO. KILDARE.
Visit us at www.aldi.com